



PEM 9 inch Ford Big Bearing Flanged Axle Order Form

Ph 636 234 0975
Fax 636 234 0982

Axle Order Information

Type of Application _____

Number of Spline? Check One.

28 spline 31 spline

Type of Brakes? Check One.

Wilwood Disc Wilwood Disc w/ E Brake

PEM Disc PEM Disc w/ E Brake

PEM Drum 10"

What type of Housing End? Check One.

Big Ford (Old Style, 1/2" bolt)

Big Ford (New Style Torino, 3/8" bolt)

Driver Side dimensions:

(A) _____

Passenger Side Dimensions:

(A) _____

Maximum axle length is 31.75"

Minimum axle length is 21.5"

Bolt pattern for wheel

5 x 4.5" Small 5 x 4.75" GM 5 x 5" Big Ford

Size of Wheel Studs

1/2" Fine Short *5/8" Fine *5/8" Coarse

1/2" Fine 3" Long All wheel studs are Press In.

Access Hole? Yes No

Turn O.D. of wheel register? _____ size

Please Provide Additional Information:

(D) _____

(E) _____

(F) _____

(G) _____

Also available is PEM's 9" Ford Axle Large Tapered Bearing Set, 3.15" OD and 1.565" ID.

PEM's part # PA-20set.

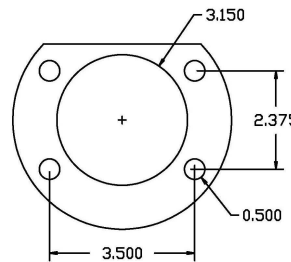
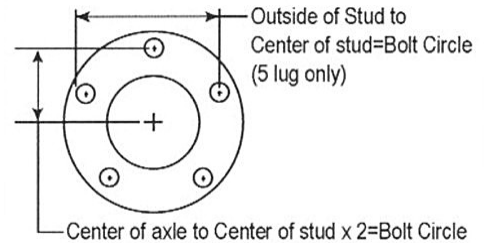
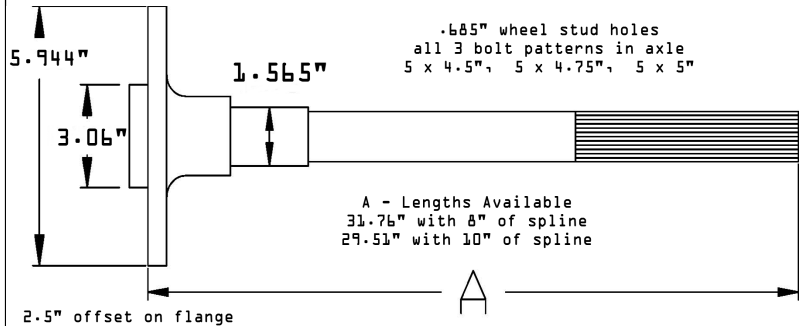

Big Ford (Old Style)

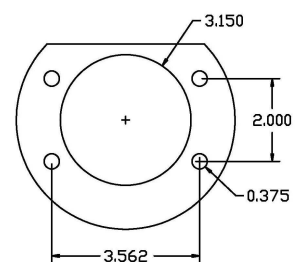

Big Ford (New Style Torino)

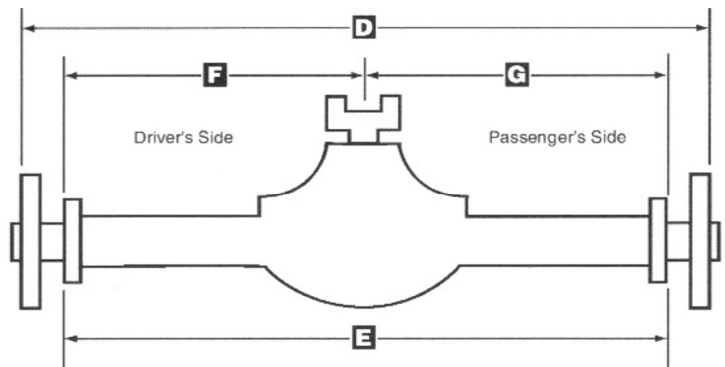

Name _____
Address _____
City _____ State ____ Zip _____
Credit Card Number _____
Exp. Date _____ 3 digit code on back _____

ALL ORDERS MUST BE ACCOMPANIED WITH COMPLETED FLANGED AXLE ORDER FORM